

**Applications**

General gate valve service where space is limited, weight needs to be minimised and non wedging bubble tight sealing is required. Available in nominal bore sizes from 16" – 72" in class ratings of 150 – 300.

Ideal for use on tank farms, manifolds, terminals, jetties and platforms and any pipeline system. Suited for vacuum service, hot tapping and a wide range of temperature and sour corrosive duties.

**Product Description***Features*

- Full round opening
- No lubrication - no routine maintenance
- Bubble-tight sealing from vacuum to full rated working pressure
- Upstream and downstream seal under all operating conditions irrespective of flow direction
- Automatic self relief of body cavity pressure resulting from thermal expansion in service fluids
- Double block and bleed as defined by API 6D
- Metal to metal primary seal
- Seat rings incorporating a secondary elastomer 'O' ring seal located in the gate and therefore out of The product flow
- Pressure formed fabricated design to achieve high strength to weight ratio and compact size
- Two piece top entry construction with bolted bonnet for in-line disassembly and ease of full seat and seal replacement
- Rising stem suitable for all types of manual and powered automation
- Pressure rated and fully tested to API 6D and BS 6755 Pt 1 pipeline valve specifications

The CORT C-G9 wafer gate valve has a compact fabricated body with integral flat ends which are drilled and tapped to suit the customers line flanges. The valve is opened by withdrawing a circular parallel slab gate including its floating seat rings into the bonnet - out of product flow.

When the gate is lowered into its preset closed position the seat rings are aligned to make a primary metal to metal seal without wedging against both the up and downstream body seat inserts.

The seats in the gate are floating and pressure energised such that the sealing action increases with increasing pipeline pressure. A secondary elastomer seal is incorporated into each seat in the



gate and springs are provided to supply the sealing force to ensure bubble tight sealing at low pressures including vacuum. No lubricant or sealant is required and therefore product contamination cannot occur from this source.

When the valve is opened the seat assemblies are lifted into the bonnet completely clear of the pipeline flow. This is far superior to gate valve designs where the seats remain unprotected in the valve body and pipeline debris can damage the face of the seats or pack behind them, resulting in the valve either leaking or jamming. It is this design feature that also means the valves are piggable.

The stem is sealed by means of two 'O' rings. When the valve is in the closed position and the body pressure bled off to atmosphere, it is possible to remove the gland for replacement of both primary and secondary stem 'O' rings.

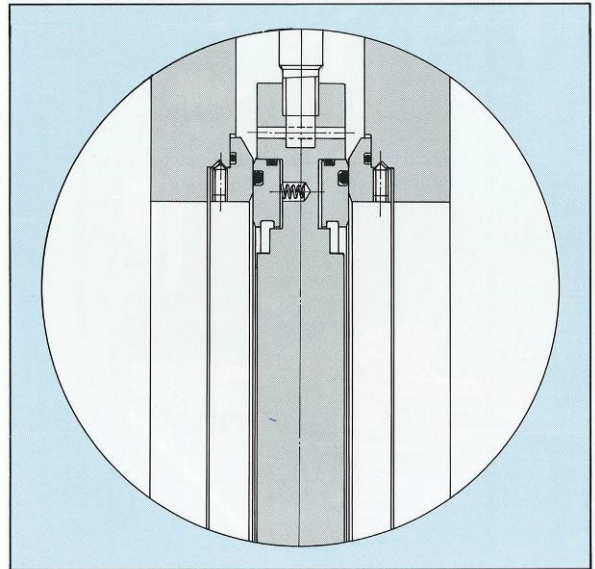

### **Range of Supply**

*Bore Sizes - 16" - 72"*

*Pressure Ratings - ANSI class 150 and 300*

### **Standard Features**

#### *Double Block and Bleed*

The C-G9 valve is ideally suited for a Double Block and Bleed service as defined by API 6D. The bubble tight seal permits the small body cavity to be vented or drained when in the closed position, with pressure applied from either side of the valve; or from both sides simultaneously under differential or balanced conditions up to the maximum pressure rating.

#### *Operators*

The C-G9 valve can be supplied with a choice of bevel gear operator suitable for one man valve operation or Electric, Pneumatic or Hydraulic actuators.

The valve can be operated with the maximum rated working pressure applied as a differential pressure without the need for equalisation.

#### *Position Indicators*

Gate position indicator rods can be supplied for attachment to the valve stem which rise through a weatherproof rubber bushing at the top of the stem protector and give positive visual indication of valve position.

### **Optional Features**

#### *Adaptor Spools*

Butt weld end pipe spools can be provided to enable customer to weld the valves directly into their pipeline without the need for transition pups.



## Product Data Sheet

C-G9 Wafer Gate Valve  
version 3.0

Spools can also be provided to increase the end to end lengths of the valves to comply fully with API 6D requirements.

### *Bolting Sets and Weld Neck Companion Flanges*

When specified, a line flange bolting set complete with nuts can be supplied for installation of the valve between a pair of standard companion flanges. Please refer to dimension details herewith for the number and size of tapped holes in the valve body.

### *Extensions*

Extensions can be supplied to enable buried or inaccessible valves to be operated from a convenient point. These are watertight extended yoke and drive tube designs which can be retrofitted with the valve under pressure.

The C-G9 valve body cavity can be piped above ground to an accessible position and completely drained down by the optional extended body drain valve system. This operation may be performed with the line under pressure and the gate in the closed position. The connections on the pipework and to the valve may be threaded, flanged or welded according to customer specification.

### *Orientation Options*

The C-G9 valve is normally installed with the stem vertical in a horizontal pipeline. Gate supports as determined by the valve size can be fitted to permit installation with the stem horizontal in either vertical or horizontal pipeline.

### *Non Rising Stem*

The Non-Rising Stem version of the Cort C-G9 gate valve gives height reduction whilst maintaining a narrow face to face dimension and retaining the standard seat design.

### *Special Designs*

Design variations for special applications including high temperature flare stack service to hazardous fire safe areas are available on request.



# Product Data Sheet

## C-G9 Wafer Gate Valve

version 3.0

### Materials

	<i>Standard</i>	<i>Options</i>
Body	Carbon Steel ASTM A36 (S275) ASTM A516 (S355)	Stainless Steel Ferralium Epoxy/Phenolic Lining
Bonnet	Carbon Steel ASTM A36 (S275) ASTM A516 (S355)	Stainless Steel Ferralium Epoxy/Phenolic Lining
Yoke	Carbon Steel ASTM A36 (S275) ASTM A106/API 5L Seamless Carbon Steel Tube)	
Body/Bonnet Bolting	ASTM A193 GRADE B7 Studs	Low Temperature Alloy Steel Ferralium Epoxy/Phenolic Lining
Gate	Carbon Steel ASTM A36 (S275) ASTM A516 (S355)	Low Temperature Carbon Steel Stainless Steel Monel Ferralium Epoxy/Phenolic Lining
Seat Rings	Electroless Nickel Coated Carbon Steel ASTM A36 (S275) ASTM A516 (S355)	LTCS 13 CR Stainless Steel 316 Stainless Steel Duplex Stainless Steel Monel Ferralium Stellite Or Tungsten Carbide
Body Seat Inserts	Electroless Nickel Coated Carbon Steel Dry Film Lubricated ASTM A36 (S275) ASTM A105	LTCS 13 CR Stainless Steel 316 Stainless Steel Duplex Stainless Steel Monel Ferralium Stellite or Tungsten Carbide
'O' Ring Seals	Nitrile (NBR)	Viton HNBR AFLAS
Stem	Electroless Nickel Coated Alloy Steel (ETG88) AISI 4140 (BS 970 709 M40)	LTCS 13 CR Stainless Steel 316 Stainless Steel 17-4 PH. Stainless Steel Monel Ferralium
Seat Springs	18/8 Austenitic Stainless Steel	Inconel X750 Monel

NOTE : Materials shown in the standard section are representative of a normal SWEET SERVICE application. Optional materials are dependent on the pressure, temperature and corrosive properties of the flow media. Further options are available upon request. Materials given in brackets include nearest equivalent European Standard designations.

For a SOUR SERVICE application, fabrication procedures and materials selected for product wetted components comply with the NACEMR-01-75.

#### Robert Cort Valves Limited

185 Elgar Road South, Reading, Berkshire, RG2 0DL

Tel: +44 (0)118 987 4311 | Fax: +44 (0)118 986 6592

Email: sales@robertcort.co.uk | Web: www.robertcort.co.uk



Part of the Flow Group  
flowgroup.co.uk  
serving the world's energy industries

#### Dimensional Outline Drawing

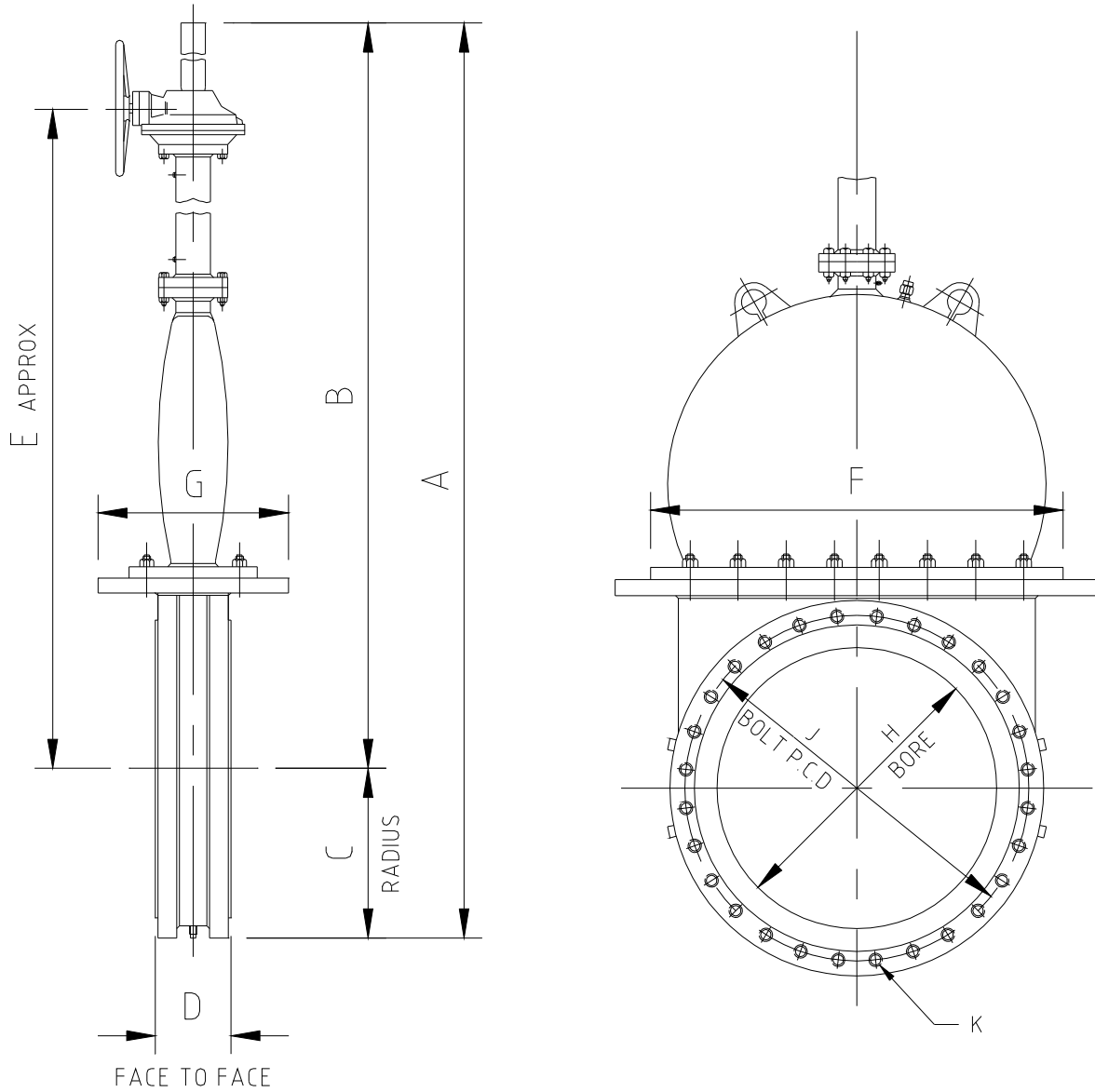



# Product Data Sheet

## C-G9 Wafer Gate Valve

version 3.0

### Weights and Dimensions Class 150

Valve Size (inch)	A	B	C	D	E	F	G	H Bore	J P.C. D	K Thread Holes (inch)		Weight (Kg)
										No.	Size	
16	2375	2076	298	184	1467	718	318	387	540	16	1-8UNC	499
18	2718	2400	318	197	1689	889	387	438	578	16	1.1/8-8N	576
20	2781	2432	349	197	1721	889	387	489	635	20	1 1/8-8N	624
22	2965	2591	374	197	1823	1003	413	540	692	20	1 1/4-8N	771
24	3188	2781	406	197	1975	1035	432	591	749	20	1 1/4-8N	884
26	3483	3048	435	197	2159	1105	470	635	806	24	1 1/4-8N	1270
28	3791	3327	464	197	2350	1245	546	686	864	28	1 1/4-8N	1324
30	3858	3366	492	197	2375	1289	559	737	914	28	1 1/4-8N	1438
32	4074	3543	530	222	2525	1384	578	781	978	28	1 1/2-8N	1587
34	4461	3905	556	222	2750	1505	641	832	1029	32	1 1/2-8N	1714
36	4509	3924	584	222	2762	1505	641	876	1086	32	1 1/2-8N	1814
40	5204	4559	645	235	3188	1765	743	978	1200	36	1 1/2-8N	2449
42	5245	4572	673	235	3213	1765	743	1022	1257	36	1 1/2-8N	2948
48	6185	5429	756	264	3880	2057	864	1168	1422	44	1 1/2-8N	4308
54	6848	6007	841	264	4275	2292	940	1314	1594	44	1 3/4-8N	5986
60	7480	6553	927	264	4667	2591	1067	1461	1759	52	1 3/4-8N	7483

### Weights and Dimensions Class 300

Valve Size (inch)	A	B	C	D	E	F	G	H Bore	J P.C. D	K Thread Holes (inch)		Weight (Kg)
										No.	Size	
16	2420	2096	324	197	1480	924	511	387	572	20	1 1/4 8N	726
18	2667	2311	356	197	1632	1026	562	438	629	24	1 1/4 8N	1020
20	2927	2540	387	210	1772	1130	625	489	686	24	1 1/4 8N	1270
22	3245	2826	419	222	1960	1219	648	540	743	24	1 1/2 8N	1496
24	3454	2997	457	222	2076	1225	660	591	813	24	1 1/2 8N	1950
26	3839	3353	486	260	2330	1410	711	635	876	28	1 5/8 8N	2450
28	4083	3565	518	260	2508	1499	737	686	940	28	1 5/8 8N	2948
30	4191	3629	562	260	2525	1524	787	737	997	28	1 3/4 8N	3356
32	4289	3714	575	298	2600	1689	895	781	1054	28	1 7/8 8N	4015
34	4918	4315	603	298	3153	1791	965	832	1105	28	1 7/8 8N	4580
36	5025	4390	635	298	3175	1791	965	876	1168	32	2 8N	4990

### Rising Stem Design

ITEM	DESCRIPTION
1	BODY UNIT
2	BONNET UNIT
4	GATE
5	SEAT RING ASSEMBLY
6	STEM
7	STEM BUSHING
8	YOKE
10	STEM DOWNSTOP
12	STUD BONNET
13	NUT BONNET
14	CAPSCREW - OPERATOR
15	CAPSCREW - LOWER YOKE
16	NUT - LOWER YOKE
17	CAPSCREW - SEAT RING
18	PIN - STEM DOWNSTOP
19	SPRING
20	STEM NUT
21	WASHER - SEAT RING
23	GASKET - OPERATOR
24	GASKET - RETAINER
25	'O' RING - STEM
26	'O' RING - SEAT RING GASKET
27	'O' RING - BONNET
28	'O' RING - STEM BUSHING
29A	GROMMET
30	STEM PROTECTOR
31	NAMEPLATE
32	EMBLEM
47	PIPE PLUG - BODY DRAIN
49	LINE FLANGE BOLTING SET
51	VENT PLUG
53	BODY SEAT INSERT
54	LOCKING SCREWS - BODY SEAT INSERT
56	'O' RING - BODY SEAT INSERT
58	ROD - VISUAL POSITION INDICATOR
59	PIN - VISUAL POSITION INDICATOR
C315	PIPE PLUG - YOKE

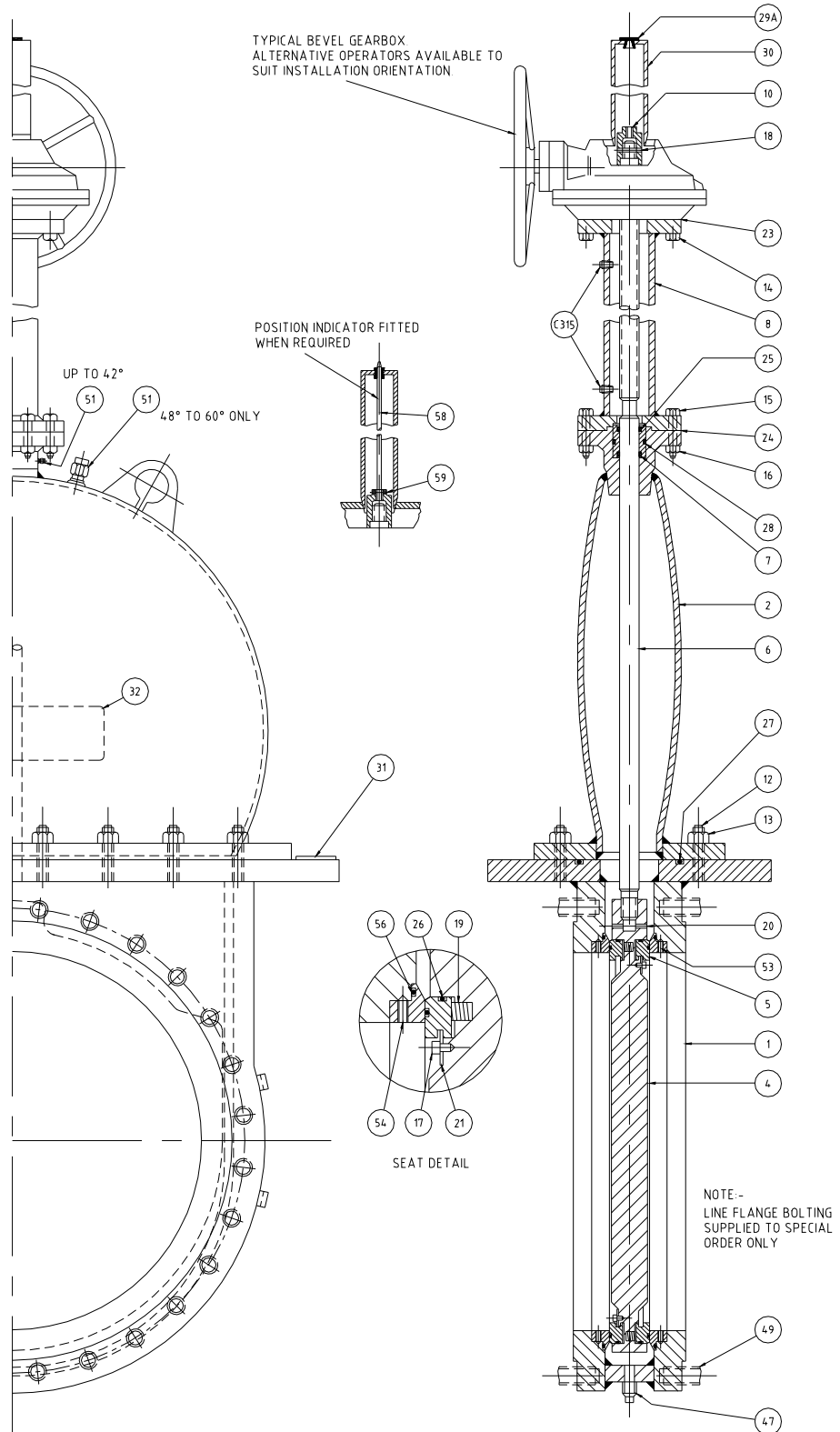

### Non-Rising Stem Design

ITEM	DESCRIPTION
1	BODY UNIT
2	BONNET UNIT
4	GATE
5	SEAT RING ASSEMBLY
6	STEM
7	STEM BUSHING
8	STEM BUSHING RETAINER
10	STEM DOWNSTOP
12	STUD BONNET
13	NUT BONNET
14	CAPSCREW - OPERATOR
17	CAPSCREW - SEAT RING
19	SPRING
20	STEM NUT
21	WASHER - SEAT RING
23	GASKET - OPERATOR
24	GASKET - RETAINER
25	'O' RING - STEM
26	'O' RING - SEAT RING GASKET
27	'O' RING - BONNET
28	'O' RING - STEM BUSHING
31	NAMEPLATE
32	EMBLEM
35	NUT - STEM
36	LOCK WASHER
47	PIPE PLUG - BODY DRAIN
49	LINE FLANGE BOLTING SET
51	VENT PLUG
53	BODY SEAT INSERT
54	LOCKING SCREWS - BODY SEAT INSERT
56	'O' RING - BODY SEAT INSERT

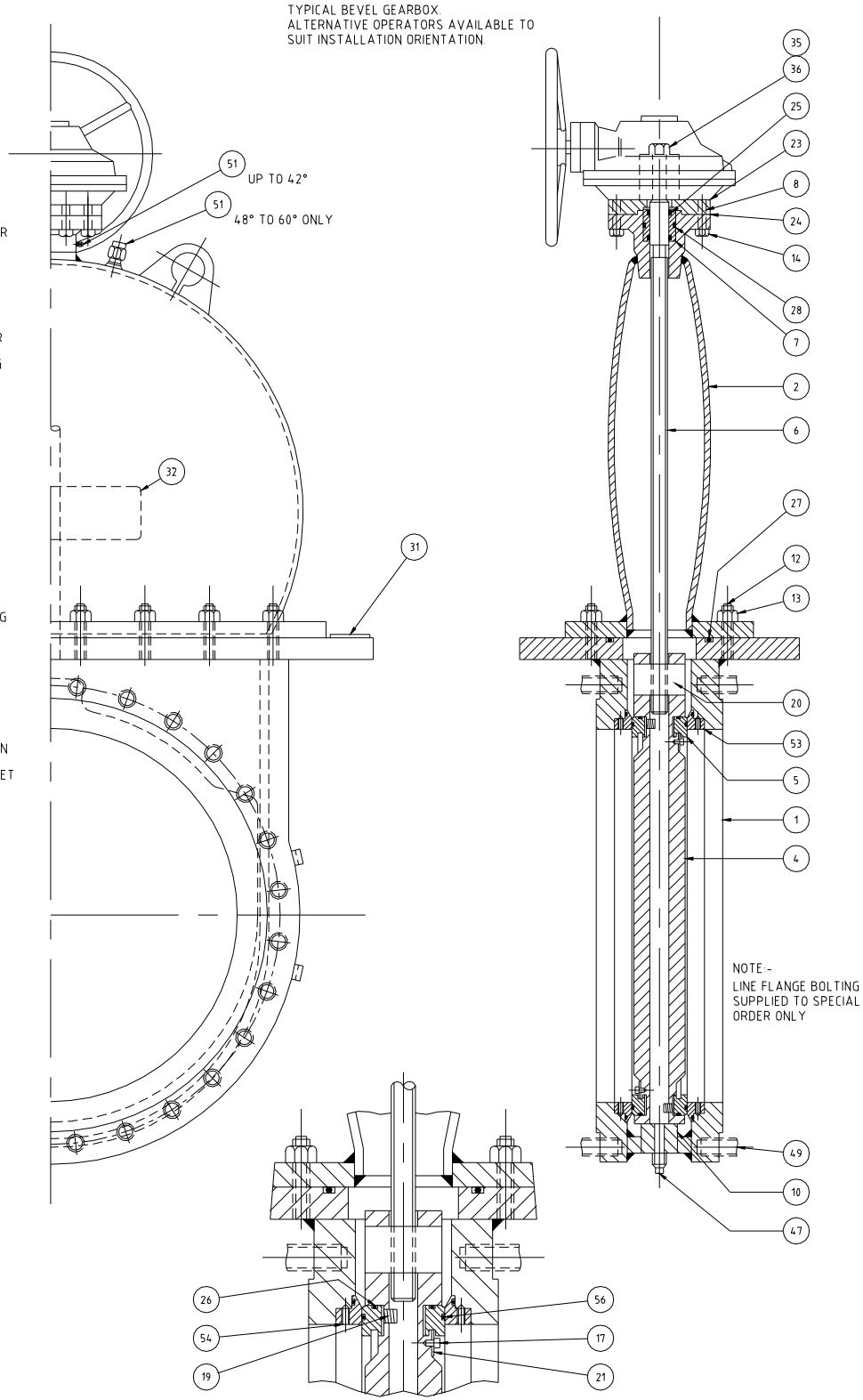



## Product Data Sheet

C-G9 Wafer Gate Valve  
version 3.0

### Applicable Standards

- API 6D Pipeline Valves
- BS 6755 Pipeline Valves
- ASME/ANSI B16.5 Pipe Flanges and Flanged Fittings (Standard for valve sizes up to and including 24")
- ASME/ANSI B16.47 Large Diameter Steel Flanges
- MSS-SP44 Steel Pipe Flanges (Standard for valve sizes 26" and above)
- API 605 Large Diameter Carbon Steel Flanges
- BS 1560 Specification for Steel Flanges
- BS 3293 Carbon Steel Pipe Flanges
- Additional standards dependent on customer specifications
- ISO 9001 Quality Assured Product

### Notes

Not certified dimensional drawings.

*All dimensions and weights are approximate. The information on this data sheet is accurate to the best of Robert Cort's knowledge; however we reserve the right to alter the product specification at any time.*

